

Technical Specifications

Princeton PB55+ 4-Way



PB+

PRINCETON
DELIVERY SYSTEMS®



Princeton PB55+ 4-Way Technical Specifications

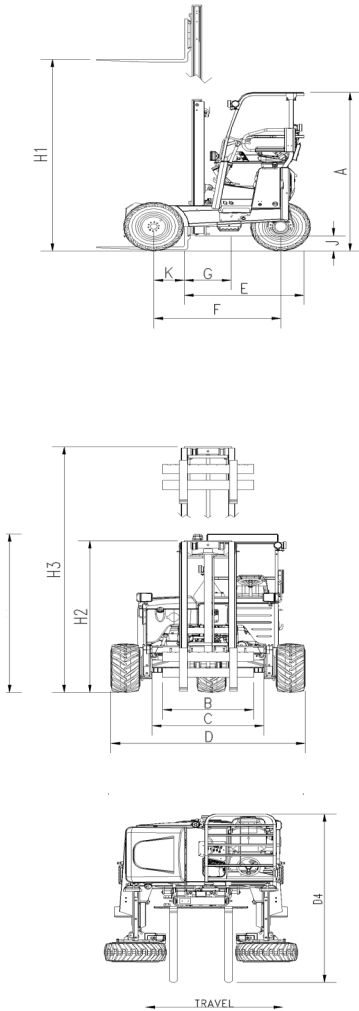

| | Model | PB55+ 4-Way |
|-----|--------------------------------------|--------------------------------------------------|
| | TYPE | 4-Way |
| 1 | CAPACITY @ 24" LOAD CENTER | 5500 lbs |
| 2 | DIESEL ENGINE | 56 HP |
| 3 | ENGINE EMISSION COMPLIANCE | EPA Tier4 Final |
| 4 | MAXIMUM RPM | 2700 RPM |
| 5 | ELECTRICAL SYSTEM | 12 Volt |
| 6 | DRIVE WHEELS | 3 |
| 7 | STEERING | Hydrostatic |
| 8 | TIRE TYPE | 31 x 13 - 16.5 (SS) 31 x 15.5 - 15 8-Ply (TG) |
| 9 | TIRE OUTSIDE DIAMETER (FRONT/REAR) | 31.5"/31" |
| 10 | TIRE WIDTH (FRONT/REAR) | 13"/15.5" |
| 11 | MAXIMUM SPEED | 7 mph |
| 12 | MAXIMUM GRADABILITY (4-WAY MODE) | 30% (15%) |
| 13 | TURNING RADIUS | 78" |
| 14 | UNLADEN WEIGHT | 6570 lbs |
| 14a | UNLADEN WEIGHT (OPTIONAL) | 7120 lbs |
| 15 | WORKING PRESSURE (ATTACHMENTS) | 2500 psi |
| 16 | TILT OF MAST (FORWARD/BACKWARD) | 10° / 8° |
| 17 | SIDESHIFT | 5" |
| 18 | FORK SECTION | 48 x 6 x 2" |
| 19 | MAST CARRIAGE TRAVEL | 31" |
| A | HEIGHT TO TOP OF CANOPY | 103" |
| B | FORK CARRIAGE WIDTH (CLASS) | 48.25" (II) |
| C | FRAME OPENING | 57.75" |
| D | OVERALL WIDTH (4-WAY MODE) | 101.25" (108) |
| E | OVERHANG | 60" |
| F | WHEELBASE | 65.5" |
| G | CENTER OF GRAVITY (FROM FORK FACE) | 17" |
| H1 | LIFT HEIGHT | 120" |
| H2 | MAST HEIGHT - COLLAPSED | 97.25" |
| H3 | MAST HEIGHT - RAISED | 157" |
| H1a | LIFT HEIGHT | 144" |
| H2a | MAST HEIGHT - COLLAPSED | 107.5" |
| H3a | MAST HEIGHT - RAISED | 179.5" |
| J | GROUND CLEARANCE | 8" |
| K | FACE OF FORK TO CENTER OF FRONT TIRE | 15" |
| L | ANSI STANDARD | B56.14 |

The above specifications are not binding upon the manufacturer and may be changed without prior notice.

Weights may vary, depending on tire and/or fork options

For more information, contact your local PiggyBack Dealer

PRINCETON

DELIVERY SYSTEMS®

Princeton Delivery Systems

12233 Williams Road

Perrysburg, OH 43551 USA

tel 1.800.331.5851

www.piggy-back.com

A Part of the Hiab Group

V2017.05.11