

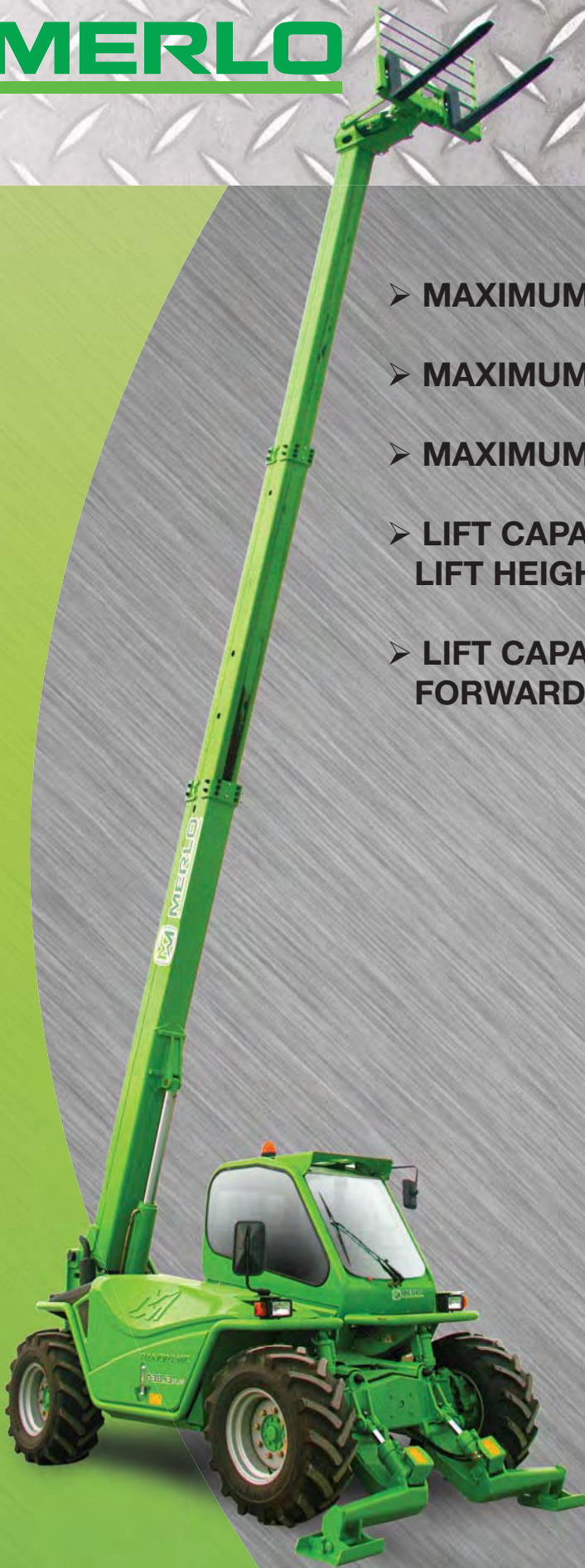

MERLO

P 38.13 STABILIZERS



- **MAXIMUM LOAD CAPACITY: 8,300 LBS**
- **MAXIMUM LIFT HEIGHT: 41' 3"**
- **MAXIMUM REACH: 28' 2"**
- **LIFT CAPACITY AT MAXIMUM LIFT HEIGHT: 7,700 LBS**
- **LIFT CAPACITY AT MAXIMUM FORWARD REACH: 1,600 LBS**

SPECIFICATIONS: P 38.13



- Power / 4 Cylinder Turbo Diesel Perkins / 101 HP
- Transmission 2 Speed /Hydrostatic
- Maximum Speed 15 MPH
- Total Unladen Mass (with forks) 19,000 LBS
- Boom Side Shift (Inches) Standard / 13
- Frame Leveling Standard / ±10%
- Load Sensing Hydraulic Pump (PSI - gal/min) .. 3,050-29
- Fuel Capacity 40 Gallons
- Hydraulic Oil Capacity 28 Gallons
- Tires 17.5-25
- Turning Radius 12'-8"
- 4 Wheel Drive / 3 Steering Modes Standard
- Hydraulic System Load-Sensing
- Independent Front Stabilizers Standard

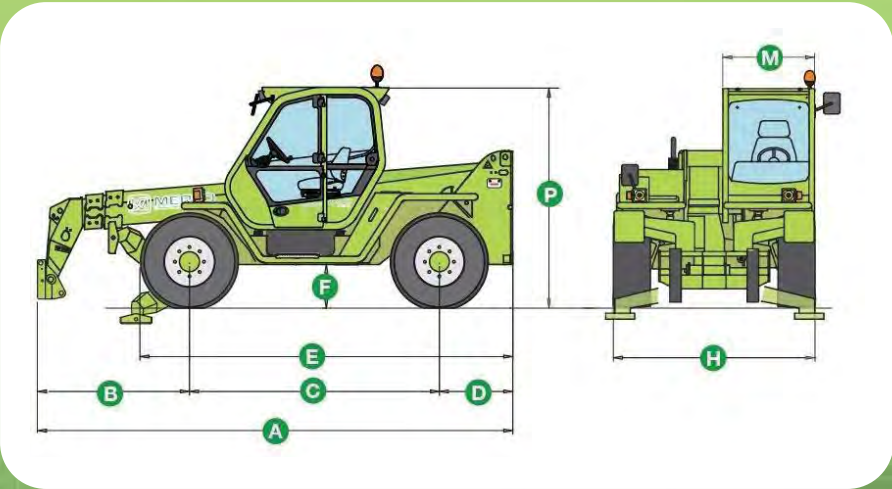
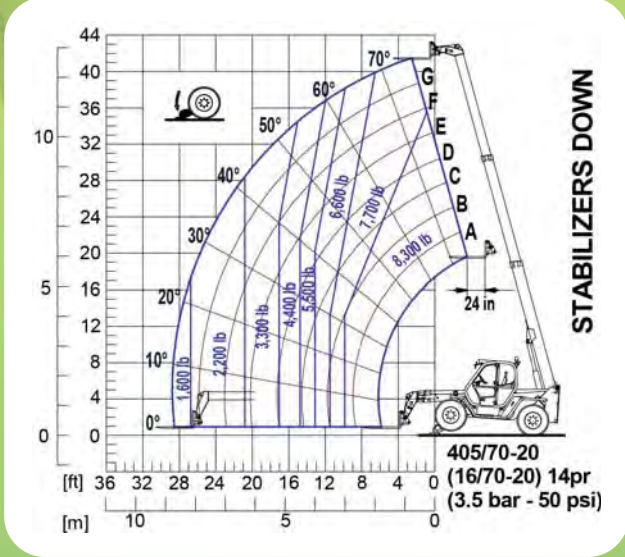
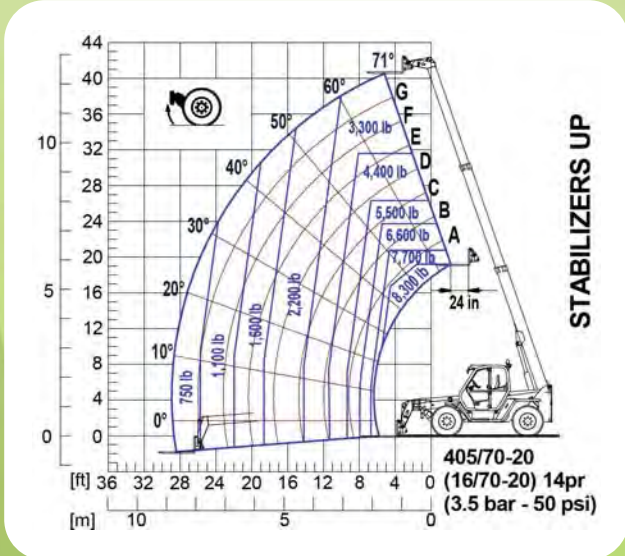

Dimensions (FT)					
A	17'-2"	D	2'-7"	H	7'-3"
B	5'-0"	E	13'-5"	M	3'-2"
C	9'-0"	F	1'-6"	P	8'-0"

DEALER INFORMATION: