

- **MAXIMUM LOAD CAPACITY: 14,300 LBS**
- **MAXIMUM LIFT HEIGHT: 45' 6"**
- **MAXIMUM REACH: 29' 5"**
- **LIFT CAPACITY AT MAXIMUM LIFT HEIGHT: 8,800 LBS**
- **LIFT CAPACITY AT MAXIMUM FORWARD REACH: 3,500 LBS**



SPECIFICATIONS: P 65.14 HM



Power / 4 Cylinder Turbo Diesel Iveco/145 HP
 Transmission 2 Speed / Hydrostatic
 Maximum Speed 25 MPH
 Total Unladen Mass (with forks) 34,100 LBS
 Boom Sideshift Standard
 Frame Leveling Standard
 Load Sensing Hydraulic Pump (PSI-gal/min) 3,335-36
 Fuel Capacity 48.8 Gallons
 Hydraulic Oil Capacity 47.5 Gallons
 Tires 17.5-25
 Turning Radius 14'-1"
 4 Wheel Drive / 3 Steering Modes Standard
 Control and Command Center Electronic MERlin

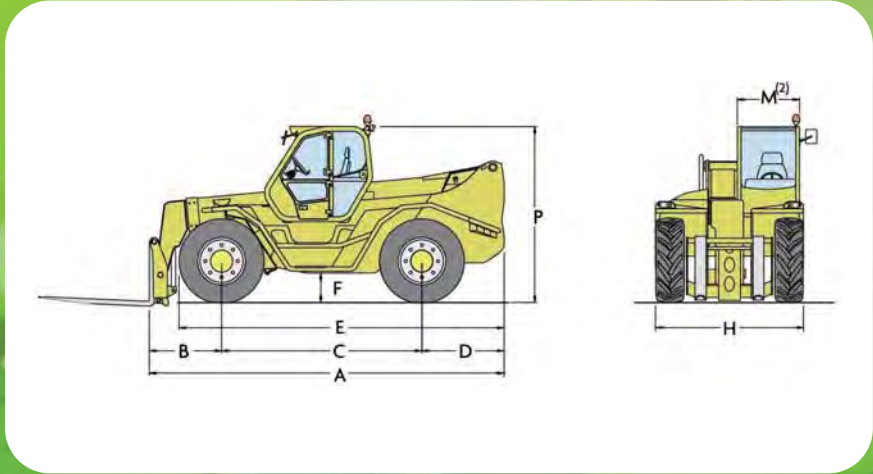
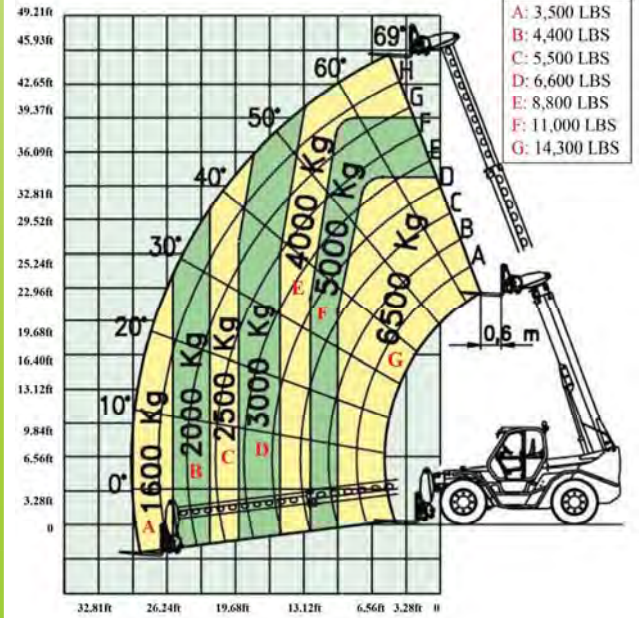

Dimensions (FT)					
A	19'-4"	D	4'-4"	H	7'-9"
B	4'-4"	E	17'-2"	M ⁽²⁾	3'-3"
C	10'-6"	F	1'-5"	P	9'-4"

(2) Internal Width

DEALER INFORMATION: